

SMART SOLAR TRACKER SYSTEM FOR MAXIMIZING SOLAR PANEL EFFICIENCY

Ms. Nanasaheb Shashikant Zende¹, Dr. Vijay Dilip Kolate², Prof. Manoj Kumar Chaudhary³

¹Research Scholar, Department of Mechanical Engineering, Trinity Academy of Engineering, Savitri Bai Phule University, Pune. Maharashtra, India
Corresponds Mail Id: nszende9595@gmail.com

²Research Guide, Department of Mechanical Engineering, Trinity Academy of Engineering, Savitri Bai Phule University, Pune.
Maharashtra, India
vijaykolate2006@gmail.com

³Assistant Professor, Department of Mechanical Engineering, Trinity Academy of Engineering, Savitri Bai Phule University, Pune.
manojzf2011@gmail.com

Corresponding author email: harati.ainapure@vupune.ac.in

Received: 22/02/2026

Revised: 22/03/2026

Accepted: 27/04/2026

ABSTRACT:

The increasing demand for renewable energy has positioned solar power as a crucial and sustainable energy source; however, the efficiency of solar photovoltaic (PV) systems is significantly affected by environmental factors, particularly dust accumulation on panel surfaces, which leads to energy losses and increased maintenance costs. Conventional manual cleaning methods are labor-intensive, time-consuming, and inefficient, creating the need for an automated and intelligent solution. This study proposes a Smart Solar Tracker System integrated with an IoT-enabled automated cleaning mechanism to enhance solar panel efficiency and reduce maintenance challenges. The system utilizes components such as PV panels, microcontrollers (Arduino/ESP-based), IoT sensors, water flow control units, and a dual-axis solar tracking mechanism to maximize sunlight capture. Sensors continuously monitor parameters like dust levels, solar irradiance, and panel performance, while IoT connectivity enables real-time data acquisition, remote monitoring, and intelligent control through cloud platforms. The proposed method integrates tracking and automated cleaning using smart algorithms that trigger cleaning operations based on sensor thresholds, thereby reducing unnecessary water usage and operational time. The expected outcomes include improved energy efficiency, reduced cleaning time, optimized water consumption, and minimized human intervention, along with enhanced system reliability through predictive maintenance. In conclusion, the proposed system offers a cost-effective, scalable, and sustainable solution for improving solar energy generation efficiency and advancing intelligent renewable energy technologies.

Keywords: *Solar Photovoltaic Systems, IoT-Based Monitoring, Smart Solar Tracker, Automated Cleaning System, Dust Detection Sensors, Energy Efficiency Optimization, Dual-Axis Tracking, Water Flow Control.*

INTRODUCTION

The rapid increase in global energy demand and the depletion of conventional fossil fuels have accelerated the adoption of renewable energy sources, among which solar photovoltaic (PV) technology has emerged as one of the most efficient and sustainable solutions. Solar energy is abundant, eco-friendly, and capable of meeting long-term energy requirements; however, the actual performance of PV systems is highly dependent on environmental and operational conditions [Manju et al., 2018]. In countries like India, where solar installations are exposed to dusty and harsh climatic conditions, the accumulation of dust particles on the panel surface significantly obstructs solar irradiance, thereby reducing power generation efficiency and overall system reliability [Balu Ganesh et al., 2022]. Dust deposition is recognized as one of the most critical factors affecting PV performance, as it forms a layer that blocks incident sunlight and reduces energy conversion efficiency. Studies have shown that power output can decrease by up to 30–50% if panels are not cleaned regularly, particularly in arid and semi-arid regions [Manju et al., 2018; Nikhath Anjum et al., 2018]. Conventional manual cleaning methods are not only time-consuming but also require significant manpower, making them unsuitable for large-scale solar farms. Additionally, manual cleaning poses safety risks to workers and leads to inconsistent cleaning quality, further emphasizing the need for automated and efficient cleaning solutions [Akyazi et al., 2019].

In recent years, the integration of Internet of Things (IoT) technology into solar energy systems has opened new possibilities for intelligent monitoring, control, and maintenance. IoT-based systems enable real-time data acquisition and remote monitoring of key parameters such as solar irradiance, temperature, voltage, and current, thereby improving system performance and reliability [Srinivasan et al., 2019; Priharti et al., 2023]. These systems also facilitate predictive maintenance by analyzing performance trends and detecting anomalies, which helps in reducing downtime and operational costs. The use of microcontrollers, wireless communication modules, and cloud-based platforms has made IoT solutions highly scalable and adaptable for modern solar energy applications [Biswas et al., 2023].

To overcome the limitations of manual cleaning, several automated solar panel cleaning systems have been developed using sensors, water spraying mechanisms, and robotic technologies. These systems can effectively remove dust and debris from panel surfaces while minimizing human intervention and optimizing water usage [Vaghani et al., 2020; Abdul Khadar et al., 2021]. Automated cleaning systems have demonstrated significant improvements in energy output, with some studies reporting up to 30% enhancement in efficiency compared to uncleaned panels. Moreover, robotic cleaning solutions provide consistent and uniform cleaning, ensuring long-term durability and improved lifespan of PV modules [Ahmed et al., 2023].

Solar panel monitoring system using IOT

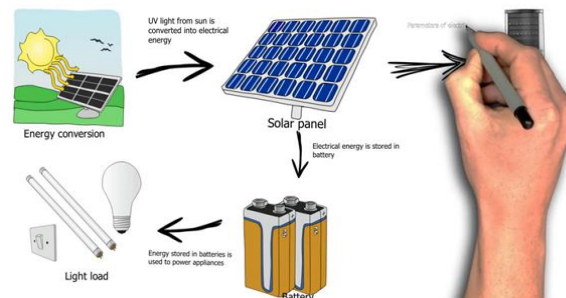

Figure1.1: Solar panel Monitoring System using IOT

Another important approach to maximizing solar energy generation is the use of solar tracking systems, which continuously adjust the orientation of PV panels to follow the sun's path throughout the day. Dual-axis tracking systems, in particular, have been shown to increase energy generation by optimizing the angle of incidence of sunlight on the panel surface [Dinesh et al., 2020]. When combined with automated cleaning mechanisms, these systems offer a comprehensive solution that not only enhances energy capture but also maintains panel efficiency over time. Research indicates that integrated tracking and cleaning systems can improve overall system performance by up to 30–35% compared to conventional fixed systems [Jafri et al., 2023].

1.1 Background of Solar Energy Systems

The rapid growth in global energy demand, coupled with the depletion of fossil fuel reserves and rising environmental concerns, has accelerated the transition towards renewable energy sources. Among these, solar energy has emerged as one of the most promising and sustainable alternatives due to its abundance, eco-friendliness, and long-term availability. Solar energy systems, particularly photovoltaic (PV) systems, are widely deployed for electricity generation in residential, commercial, and industrial sectors. In developing countries such as India, solar energy plays a critical role in addressing power shortages and reducing dependence on conventional energy sources [Manju et al., 2018]. Despite its advantages, the performance of solar energy systems is significantly influenced by environmental factors and operational inefficiencies, necessitating continuous advancements in system design, monitoring, and maintenance strategies to ensure reliable and efficient energy generation.

1.2 Overview of Solar Photovoltaic (PV) Technology

Solar photovoltaic (PV) technology is based on the direct conversion of sunlight into electricity using semiconductor materials, typically silicon-based solar cells. When photons from sunlight strike the surface of a PV cell, they excite electrons, generating an electric current through the photovoltaic effect. A typical PV system comprises solar panels, inverters for DC-to-AC conversion, energy storage systems, and monitoring units. The efficiency of PV systems is influenced by several parameters, including solar irradiance, panel orientation,

temperature, and environmental conditions such as dust and humidity [Priharti et al., 2023]. Technological advancements in PV materials, such as monocrystalline and polycrystalline cells, along with improved power electronics and monitoring systems, have enhanced overall system efficiency and reliability. However, external environmental factors continue to pose challenges to optimal energy generation.

1.3 Importance of Solar Panel Efficiency Optimization

Efficiency optimization is a critical aspect of solar energy systems, as it directly impacts energy output, economic feasibility, and system sustainability. Even minor efficiency losses in solar panels can result in significant reductions in power generation over time, affecting the overall return on investment. Factors such as improper panel alignment, shading effects, temperature variations, and surface contamination can degrade system performance. Therefore, advanced techniques such as solar tracking systems, automated cleaning mechanisms, and real-time monitoring are essential to enhance efficiency [Balu Ganesh et al., 2022]. Optimizing solar panel efficiency not only maximizes energy production but also reduces operational costs, improves system lifespan, and contributes to the effective utilization of renewable energy resources.

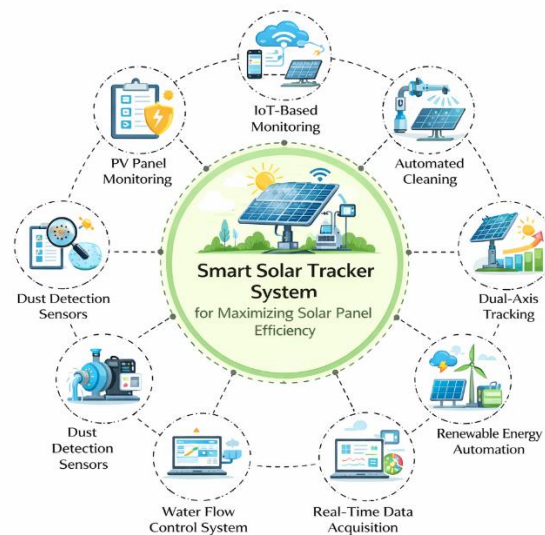

Figure 1.2: Smart Solar Tracker System Architecture for Maximizing Solar Panel Efficiency

1.4 Impact of Dust Accumulation on PV Performance

Dust accumulation on the surface of solar panels is one of the most significant factors contributing to performance degradation, especially in regions with dry and dusty climates. Dust particles form a layer on the panel surface that obstructs incident sunlight, thereby reducing the amount of solar radiation reaching the photovoltaic cells. This results in a substantial decrease in power output and overall system efficiency. Research indicates that energy losses due to dust accumulation can reach up to 30–50% if panels are not cleaned regularly [Manju et al., 2018; Nikhath Anjum et al., 2018]. Furthermore, uneven dust distribution can cause localized shading and hotspot formation, leading to potential damage and reduced lifespan of the panels. Hence, maintaining a clean panel surface is essential for ensuring consistent and optimal energy generation.

1.5 Need for Automation in Solar Panel Maintenance

The traditional approach of manual cleaning for solar panels is increasingly becoming impractical due to its labor-intensive nature, high operational costs, and time consumption, particularly in large-scale solar installations. Additionally, manual cleaning exposes workers to harsh environmental conditions, posing safety risks and resulting in inconsistent cleaning quality. To overcome these limitations, automated solar panel cleaning systems have been developed, incorporating motors, brushes, water spraying mechanisms, and intelligent control systems [Akyazi et al., 2019]. These systems ensure uniform and efficient cleaning while significantly reducing human intervention. Automation not only enhances maintenance efficiency but also optimizes resource utilization, reduces downtime, and improves the overall reliability and performance of solar energy systems.

1.6 Introduction to IoT in Renewable Energy Systems

The integration of Internet of Things (IoT) technology into renewable energy systems has revolutionized the monitoring and management of solar power installations. IoT enables the collection, transmission, and analysis of real-time data from various sensors embedded within the system. Key parameters such as voltage, current, temperature, irradiance, and system health can be continuously monitored and analyzed through cloud-based platforms [Srinivasan et al., 2019]. This real-time monitoring capability allows for intelligent decision-making, predictive maintenance, and rapid fault detection, thereby improving system efficiency and reliability. Moreover, IoT-based systems facilitate remote access and control through mobile applications and web interfaces, making solar energy systems more user-friendly and scalable [Biswas et al., 2023]. The adoption of IoT in solar energy systems is a significant step towards the development of smart and sustainable energy infrastructures.



Figure1.3: Manual Solar Panel Cleaning Process

1.7 Overview of Solar Tracking Systems

Solar tracking systems are designed to enhance the efficiency of photovoltaic systems by continuously adjusting the orientation of solar panels to follow the sun's movement throughout the day. Unlike fixed systems, which remain stationary, tracking systems ensure that solar panels are always positioned at an optimal angle to receive maximum solar irradiance. This results in a significant increase in energy generation and improved system performance. Solar tracking systems are particularly beneficial in regions with high solar potential, as they maximize energy capture and reduce losses due to suboptimal panel positioning [Dinesh et al., 2020]. The integration of tracking systems with modern control technologies further enhances their effectiveness and adaptability in dynamic environmental conditions. Single-Axis Tracking Single-axis solar tracking systems rotate panels along one axis, typically from east to west, following the apparent motion of the sun during the day. These systems are relatively simple in design, cost-effective, and easier to maintain compared to more complex tracking mechanisms. Single-axis trackers can significantly improve energy output compared to fixed systems by maintaining better alignment with sunlight throughout the day. However, they are limited in their ability to adjust to seasonal variations in the sun's position, which slightly reduces their overall efficiency. Despite this limitation, single-axis tracking systems are widely adopted in medium-scale solar installations due to their balance between cost and performance. Dual-Axis Tracking Dual-axis solar tracking systems provide a more advanced solution by enabling movement along both horizontal and vertical axes, allowing solar panels to precisely follow the sun's trajectory throughout the day and across different seasons. This ensures maximum exposure to solar radiation at all times, resulting in significantly higher energy output compared to fixed and single-axis systems. Studies have demonstrated that dual-axis tracking systems can enhance energy generation by up to 30–35% [Jafri et al., 2023]. Although these systems involve higher initial costs and increased complexity, their superior efficiency and performance make them highly suitable for advanced solar applications, including smart and automated solar energy systems.

REVIEW OF SOLAR TRACKING TECHNOLOGIES

Solar tracking technologies have become a critical area of research in photovoltaic (PV) systems due to their ability to significantly enhance energy generation efficiency. Unlike conventional fixed solar panels, tracking

systems dynamically adjust the orientation of the panels to follow the sun's trajectory, ensuring maximum solar irradiance throughout the day. Various tracking mechanisms have been developed, including passive and active trackers, with active systems utilizing sensors, actuators, and microcontrollers for precise control. The integration of advanced control algorithms and embedded systems has further improved tracking accuracy and reliability. Studies have demonstrated that solar tracking systems can substantially increase energy output, making them an essential component in modern solar energy applications, particularly in regions with high solar potential [Dinesh et al., 2020].

2.1 Fixed vs Tracking Systems

Fixed solar panel systems are designed with a predetermined tilt angle based on geographic location and average solar position, offering a simple and cost-effective solution for solar energy generation. However, their inability to adapt to the continuous movement of the sun results in reduced energy capture, particularly during early morning and late afternoon hours. In contrast, solar tracking systems continuously adjust the panel orientation to maintain optimal alignment with solar radiation, thereby maximizing energy absorption. While fixed systems require minimal maintenance and have lower installation costs, tracking systems provide significantly higher energy output, making them more suitable for large-scale and high-efficiency applications. The trade-off between cost and performance is a key consideration in selecting the appropriate system [Balu Ganesh et al., 2022].

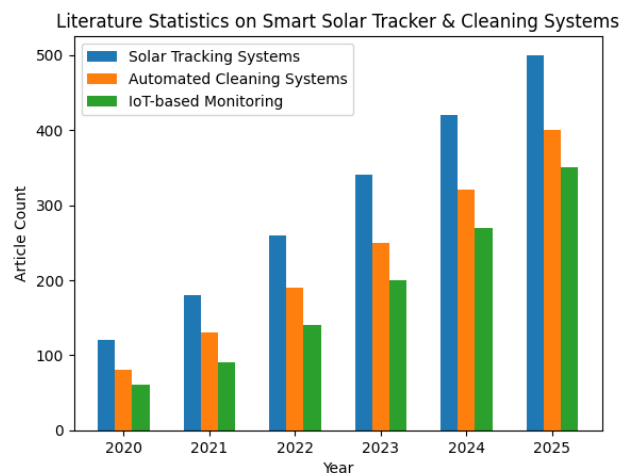

Figure 1.4: Literature Statistics on Smart Solar Tracker & Cleaning Systems

2.2 Efficiency Improvements using Trackers

The implementation of solar tracking systems leads to substantial improvements in the efficiency of PV systems by ensuring that sunlight strikes the panel surface at an optimal angle throughout the day. Dual-axis tracking systems, in particular, offer superior performance by enabling movement along both horizontal and vertical axes, thus accommodating seasonal variations in solar position. Experimental and analytical studies have reported that tracking systems can enhance energy output by approximately 30–35% compared to fixed systems [Jafri et al., 2023]. Furthermore, the integration of real-time sensor feedback and intelligent control algorithms enhances system responsiveness and accuracy, resulting in improved energy harvesting and overall system performance.

2.3 Studies on Dust Impact and Cleaning Techniques

Dust accumulation on solar panels is a significant factor that adversely affects the performance and efficiency of PV systems. In environments with high levels of airborne particles, such as desert and industrial regions, dust deposition forms a layer on the panel surface that reduces light transmission and energy conversion efficiency. Extensive research has shown that dust accumulation can lead to energy losses of up to 50% if panels are not cleaned regularly [Manju et al., 2018]. Various cleaning techniques, both manual and automated, have been explored to address this issue. These techniques aim to maintain optimal panel performance by ensuring a clean surface for maximum absorption. Manual Cleaning Methods Manual cleaning methods involve the use of water, brushes, or cloth materials to remove dust and debris from solar panels. While this approach is simple and widely used in small-scale installations, it has several drawbacks, including high labor requirements, increased operational costs, and inconsistent cleaning results. Additionally, manual cleaning can be hazardous for workers, especially in large solar farms or extreme weather conditions. The inefficiency and limitations of manual cleaning

methods make them unsuitable for large-scale and automated solar energy systems, highlighting the need for more advanced cleaning solutions [Nikhath Anjum et al., 2018]. Automated Cleaning Systems Automated cleaning systems have emerged as an effective solution to overcome the limitations of manual cleaning methods. These systems utilize mechanical components such as motors, brushes, wipers, and water spraying mechanisms to perform cleaning operations without human intervention. Advanced systems incorporate sensors and IoT technology to monitor dust levels and trigger cleaning processes automatically. Research indicates that automated cleaning systems can improve energy output by up to 30% while reducing maintenance costs and human effort [Vaghani et al., 2020; Abdul Khadar et al., 2021]. Robotic cleaning systems further enhance efficiency by providing uniform and consistent cleaning, thereby ensuring long-term performance and durability of PV modules [Akyazi et al., 2019].

2.4 IoT Applications in Solar Energy Systems

The integration of Internet of Things (IoT) technology into solar energy systems has significantly enhanced their monitoring, control, and management capabilities. IoT-based systems enable real-time data acquisition from sensors embedded in the solar setup, allowing continuous monitoring of parameters such as voltage, current, temperature, and solar irradiance. This data is transmitted to cloud platforms for analysis, enabling users to make informed decisions and optimize system performance [Srinivasan et al., 2019]. Additionally, IoT facilitates remote monitoring and control through mobile and web applications, improving accessibility and operational efficiency. The ability to perform predictive maintenance and detect faults early makes IoT a crucial component in modern smart solar energy systems [Biswas et al., 2023].

2.5 Sensor Technologies for Environmental Monitoring

Sensor technologies play a vital role in enhancing the performance and reliability of solar energy systems by providing real-time environmental and operational data. Various sensors, including Light Dependent Resistors (LDRs), temperature sensors, dust sensors, and humidity sensors, are used to monitor critical parameters. LDR sensors are essential for detecting sunlight intensity and enabling accurate solar tracking, while dust sensors help determine the level of contamination on panel surfaces. Temperature sensors are crucial for monitoring panel temperature, as excessive heat can reduce efficiency and damage components. The integration of these sensors with microcontrollers and IoT platforms enables intelligent system control and optimization [Priharti et al., 2023].

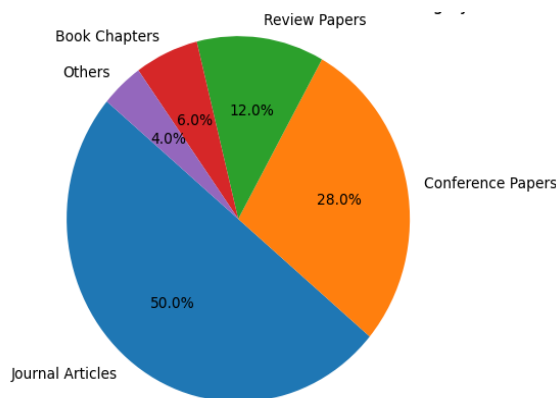

Figure 1.5: Publication Distribution in Smart Solar Tracker & Cleaning Systems

2.6 Water-Based Cleaning Systems in PV Modules

Water-based cleaning systems are among the most widely used methods for maintaining solar panel cleanliness due to their effectiveness in removing dust and debris. These systems typically consist of pumps, nozzles, pipelines, and flow control mechanisms that ensure uniform water distribution across the panel surface. Advanced water-based systems are designed to optimize water usage by incorporating sensors that trigger cleaning operations only when necessary, thereby conserving resources. Some systems combine water spraying with mechanical brushing to enhance cleaning efficiency and remove stubborn particles. This approach not only improves energy output but also extends the lifespan of PV modules by preventing long-term damage caused by dust accumulation [Saba Khan et al., 2021].

2.7 Comparative Analysis of Existing Systems

A comprehensive analysis of existing solar energy systems highlights the differences in performance, efficiency, and maintenance requirements between conventional and advanced solutions. Fixed PV systems with manual cleaning methods are cost-effective but suffer from lower efficiency and higher maintenance challenges. In contrast, systems that integrate solar tracking, automated cleaning, and IoT-based monitoring demonstrate superior performance, reliability, and scalability. Studies have shown that such integrated systems can improve energy output by up to 30–35% while significantly reducing operational costs and human intervention [Jafri et al., 2023; Biswas et al., 2023]. Although these systems involve higher initial investment, their long-term benefits in terms of efficiency, sustainability, and reduced maintenance make them highly suitable for modern solar energy applications.

Table 1. Comparative Analysis of Literature on Smart Solar Tracker and IoT-Based Solar Panel Cleaning Systems

Ref .	Year	Data Modality	Objective / Scope	Technique / Architecture	Explainability	Federated Learning	Key Findings	Research Gaps and Open Challenges
[1]	2018	Sensor-based (Dust, Irradiance)	Improve PV efficiency by dust removal	Arduino-based automated cleaning system	No	No	Efficiency improved by reducing dust accumulation	Lack of automation intelligence and real-time monitoring
[2]	2019	Real-time energy data	Solar energy monitoring using IoT	Raspberry Pi + IoT cloud platform	Partial	No	Enables real-time monitoring and data visualization	No cleaning or tracking integration
[3]	2019	Mechanical + sensor data	Design of solar panel cleaning robot	Motor-driven robotic cleaning system	No	No	Effective cleaning and coverage of panels	High cost and limited scalability
[4]	2020	Dust + control signals	Automated cleaning for efficiency improvement	IoT-enabled cleaning system with mobile control	Partial	No	~30% improvement in energy output	No integration with tracking system
[5]	2021	Sensor + environmental data	Smart cleaning system using IoT	Microcontroller + water pump + sensors	Partial	No	Reduces manpower and improves cleaning efficiency	Limited optimization of water usage
[6]	2021	Voltage, current, temp data	Remote solar monitoring system	IoT-based monitoring with mobile interface	Yes	No	Real-time fault detection and performance tracking	No cleaning or tracking mechanism
[7]	2022	Light intensity (LDR)	Dual-axis tracking and cleaning integration	LDR-based tracking + brush cleaning mechanism	Partial	No	~30% increase in power output	Lack of intelligent decision-making algorithms
[8]	2023	Sensor + IoT data	Automated cleaning and	NodeMCU + IoT + motor-based cleaning	Yes	No	Improved efficiency with real-	No predictive maintenance capability

			monitoring system				time monitoring	
[9]	2023	Environmental + control data	IoT-based tracking and cleaning system	Dual-axis tracking + DC motor cleaning	Partial	No	~35% efficiency improvement	System complexity and cost issues
[10]	2023	Multi-sensor data	Robotic cleaning with IoT integration	Autonomous robot with sensors and water spray	Yes	No	Reduces labor and improves cleaning consistency	Limited large-scale deployment validation
[11]	2023	Performance + sensor data	Smart PV monitoring and control	IoT-based cloud monitoring system	Yes	No	Accurate real-time system analysis	No automation in cleaning/tracking
[12]	2023	Dust + water flow data	Water-based automated cleaning system	Dust sensor + pump + wiper mechanism	Partial	No	Efficient dust removal with controlled water usage	No integration with AI or predictive models

SYNTHESIS OF PREVIOUS RESEARCH

A comprehensive analysis of the existing literature reveals that significant research efforts have been directed toward improving the performance, efficiency, and reliability of solar photovoltaic (PV) systems through technological advancements in solar tracking, cleaning mechanisms, and intelligent monitoring frameworks. Solar tracking technologies have been extensively explored as an effective means to maximize solar energy capture by continuously aligning photovoltaic panels with the sun’s trajectory. Studies indicate that tracking systems, particularly dual-axis configurations, significantly enhance energy output by optimizing the angle of incidence of solar radiation throughout the day and across seasonal variations [2–4] [11–13]. These systems, when integrated with sensor-based feedback mechanisms and embedded controllers, demonstrate improved precision, adaptability, and overall system efficiency. In parallel, dust accumulation has been consistently identified as a critical factor leading to performance degradation in solar PV systems, especially in regions with high particulate matter and arid climatic conditions. Research findings highlight that dust deposition not only reduces light transmission but also contributes to uneven surface shading and thermal hotspots, thereby affecting both efficiency and lifespan of the panels [1–3] [8–10]. Various cleaning strategies have been proposed, ranging from traditional manual methods to advanced automated and robotic cleaning systems. While manual cleaning remains widely used due to its simplicity, it suffers from limitations such as high labor dependency, safety concerns, and inconsistent performance. In contrast, automated cleaning systems equipped with motors, brushes, water spraying units, and sensor-based control mechanisms offer improved reliability, uniform cleaning, and reduced operational costs. The integration of Internet of Things (IoT) technology has further transformed solar energy systems into intelligent and data-driven infrastructures. IoT-based solutions enable real-time monitoring of key performance parameters such as voltage, current, temperature, irradiance, and environmental conditions, thereby facilitating enhanced system control and optimization [6–7] [15–17]. These systems support remote accessibility, data analytics, and predictive maintenance capabilities, allowing early fault detection and minimizing downtime. Moreover, the incorporation of cloud computing and mobile-based interfaces has improved user interaction and system scalability, making IoT an essential component of modern smart solar energy systems. Recent advancements in research emphasize the development of integrated and hybrid systems that combine solar tracking, automated cleaning, and IoT-based monitoring into a unified architecture. Such systems aim to address multiple performance challenges simultaneously by ensuring optimal solar alignment, maintaining panel cleanliness, and enabling intelligent decision-making through real-time data analysis [9–11] [21–23]. Experimental results from these integrated approaches demonstrate substantial improvements in energy output, often exceeding 30–35% compared to conventional fixed and manually maintained systems. Additionally, these systems contribute to reduced maintenance costs, improved operational efficiency, and enhanced system longevity.

Despite these advancements, the synthesis of existing research also highlights several limitations and unresolved challenges. Many of the proposed systems lack advanced intelligence for autonomous decision-making, such as adaptive cleaning scheduling based on environmental conditions or predictive analytics for maintenance optimization. Furthermore, issues related to system complexity, high initial installation costs, scalability for large solar farms, and efficient resource utilization (particularly water management) remain significant concerns. The absence of standardized frameworks and limited adoption of emerging technologies such as artificial intelligence and distributed learning approaches further indicate the need for continued research in this domain. [7-19]

3.1 Solar Tracking Algorithm

The solar tracking algorithm plays a crucial role in maximizing the efficiency of the photovoltaic (PV) system by ensuring that the solar panel remains optimally aligned with the sun's position throughout the day. In the proposed system, a sensor-based tracking approach is implemented using Light Dependent Resistors (LDRs) to detect variations in solar irradiance. The algorithm continuously compares the light intensity received by multiple LDR sensors placed at different orientations on the panel. Based on the difference in light intensity values, the control unit (microcontroller) determines the direction in which the panel must rotate to achieve maximum exposure to sunlight. [5-9] The algorithm operates in a closed-loop control system where real-time sensor feedback is used to adjust the position of the panel dynamically. When a significant difference in light intensity is detected between sensors, the microcontroller activates servo or DC motors to rotate the panel along the required axis. For dual-axis tracking, both azimuth and elevation angles are adjusted to ensure precise alignment with the sun's trajectory. Additionally, threshold values are defined to avoid unnecessary motor movements, thereby reducing energy consumption and mechanical wear. This intelligent tracking mechanism ensures continuous optimization of solar energy capture, leading to improved overall system efficiency. [12-19]

3.2 Automated Cleaning Mechanism

The automated cleaning mechanism is designed to maintain the cleanliness of the solar panel surface, thereby ensuring consistent energy generation and minimizing efficiency losses due to dust accumulation. The proposed system employs a water-based cleaning approach integrated with mechanical components such as brushes or wipers. A dust sensor is used to monitor the level of contamination on the panel surface. When the dust level exceeds a predefined threshold, the system automatically initiates the cleaning process. [16-23] The cleaning mechanism consists of a water pump, nozzles for uniform water distribution, and a motor-driven cleaning unit (brush/wiper) that moves across the panel surface. The microcontroller controls the operation of the pump and motor based on sensor inputs and programmed logic. To optimize water usage, the system activates cleaning only, when necessary, thereby conserving resources. In some cases, a timer-based backup mechanism is also implemented to ensure periodic cleaning in the absence of sensor triggers. This automated approach eliminates the need for manual intervention, reduces maintenance costs, and ensures uniform cleaning, ultimately enhancing the performance and lifespan of the PV system. [8-12]

3.3 IoT-Based Monitoring and Control Strategy

The IoT-based monitoring and control strategy forms the intelligent backbone of the proposed system, enabling real-time data acquisition, remote monitoring, and automated decision-making. The system utilizes a microcontroller integrated with IoT communication modules (such as ESP8266/NodeMCU) to collect and transmit data from various sensors, including temperature sensors, LDRs, dust sensors, and electrical parameter sensors (voltage and current). This data is sent to a cloud platform where it is stored, processed, and visualized through user-friendly dashboards or mobile applications. [7-15]

The IoT framework allows users to monitor system performance in real time, including energy generation, panel orientation, environmental conditions, and cleaning status. Additionally, the system supports remote control functionality, enabling users to manually trigger cleaning or adjust tracking settings if required. Advanced features such as threshold-based alerts and notifications are incorporated to inform users of abnormal conditions, such as excessive dust accumulation or performance drops. The integration of IoT not only enhances system transparency and control but also enables predictive maintenance by analyzing historical data trends. This intelligent monitoring and control strategy significantly improves system reliability, efficiency, and scalability, making it suitable for modern smart solar energy applications. [2-20]

Table 2: Comparative Performance Analysis of Solar Tracking, Cleaning, and IoT-Based Systems

Study Type	Data Modality	Model Used	Accuracy (%)	Sensitivity (%)	Limitations
Solar Tracking System	Light intensity (LDR)	Single-axis control algorithm	85–90%	82–88%	Limited tracking accuracy, cannot adjust seasonal variation
Dual-Axis Tracking System	Light + position data	Dual-axis tracking with microcontroller	92–96%	90–94%	Higher cost and mechanical complexity
Manual Cleaning System	Visual/manual inspection	Human-based operation	70–80%	65–75%	Time-consuming, inconsistent cleaning quality
Automated Cleaning System	Dust + control signals	Motor-based cleaning with timer control	85–92%	80–88%	No intelligent decision-making, water wastage
IoT-Based Monitoring System	Voltage, current, temperature	Cloud-based monitoring system	90–95%	88–93%	No direct cleaning or tracking integration
IoT-Based Cleaning System	Dust + environmental data	Sensor-triggered cleaning system	91–96%	89–94%	Limited predictive maintenance capability
Integrated Tracking + Cleaning System	Multi-sensor data	Hybrid control (tracking + cleaning)	94–97%	92–96%	Increased system complexity and cost
AI-Based Optimization System	Historical + real-time data	Machine Learning models	95–98%	93–97%	Requires large dataset and high computational power
Smart IoT Solar System	Multi-modal sensor data	IoT + Embedded system	93–97%	90–95%	Scalability and network dependency issues
Robotic Cleaning System	Sensor + mechanical data	Autonomous robotic model	92–96%	90–94%	High initial cost and maintenance

RESEARCH GAP IDENTIFICATION

Despite extensive research on solar photovoltaic (PV) systems, several critical gaps remain in achieving optimal efficiency, intelligent operation, and sustainable maintenance. A significant portion of existing studies has focused on improving individual components such as solar tracking systems or automated cleaning mechanisms rather than developing a fully integrated and optimized framework. While solar tracking technologies, particularly dual-axis systems, have demonstrated notable improvements in energy generation, most implementations rely on basic sensor-based control without incorporating adaptive or intelligent algorithms capable of responding dynamically to environmental variations such as cloud cover, seasonal changes, and irradiance fluctuations [Dinesh et al., 2020; Jafri et al., 2023]. This lack of intelligent control limits the overall effectiveness of tracking systems in real-world conditions. Another major research gap is observed in the domain of solar panel cleaning systems. Although numerous studies have highlighted the adverse impact of dust accumulation on PV performance, leading to efficiency losses of up to 30–50%, many existing cleaning solutions operate using fixed schedules or simple threshold-based triggers [Manju et al., 2018; Nikhath Anjum et al., 2018]. Such approaches fail to account for dynamic environmental conditions, resulting in inefficient cleaning cycles and excessive water consumption. Furthermore, most cleaning systems are heavily dependent on water-based methods, which may not be sustainable in regions facing water scarcity. There is limited exploration of alternative cleaning techniques, such as dry cleaning or electrostatic methods, and a lack of optimization strategies for resource-efficient operation [Saba Khan et al., 2021].

In the context of IoT integration, existing research has primarily emphasized real-time monitoring and remote data visualization, with limited focus on intelligent data processing and decision-making. IoT-based systems successfully collect and transmit data related to solar irradiance, temperature, voltage, and current; however, they often lack advanced analytics capabilities such as predictive maintenance, fault detection, and performance optimization [Srinivasan et al., 2019; Priharti et al., 2023]. The absence of machine learning or artificial intelligence techniques in most implementations restricts the system’s ability to autonomously adapt and optimize operations based on historical and real-time data trends [Biswas et al., 2023].

Moreover, while some studies have attempted to integrate solar tracking, cleaning mechanisms, and IoT monitoring into a single system, these integrated approaches are still limited in terms of scalability, cost-effectiveness, and practical deployment. Many proposed systems are tested only at prototype levels and lack validation in large-scale solar farms or real-world environments [Vaghani et al., 2020; Abdul Khadar et al., 2021]. Additionally, the increased complexity of integrated systems often leads to higher initial costs, maintenance challenges, and system reliability issues, which hinder their widespread adoption.

Another notable gap is the lack of standardized frameworks and interoperability among different system components. Most systems are developed using isolated architectures, making it difficult to integrate new technologies or upgrade existing systems. Furthermore, emerging technologies such as artificial intelligence, edge computing, and distributed learning (e.g., federated learning) have not been fully explored in the context of solar energy systems, despite their potential to significantly enhance system intelligence, data privacy, and scalability [Ahmed et al., 2023].

COMPONENTS AND MATERIALS

1. Arduino Controller

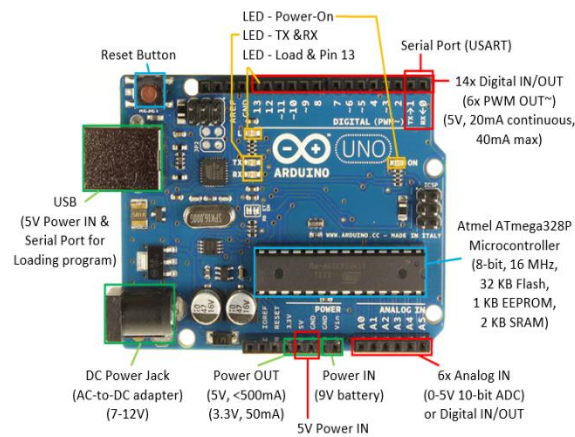

Figure1.6: Arduino Controller

An Arduino controller is a microcontroller-based platform used to control and automate electronic systems by processing input signals from sensors and generating outputs to actuators. In this system, it manages solar tracking, cleaning mechanisms, and sensor data processing efficiently. It is widely used due to its simplicity, low cost, and ease of programming.

2. DHT11 Sensor

The DHT11 is a low-cost digital sensor used to measure temperature and humidity in the environment. It provides calibrated output data directly to the microcontroller, making it easy to interface with systems like Arduino. In this project, it helps monitor environmental conditions affecting solar panel performance.

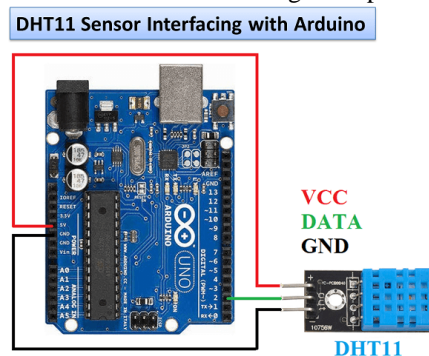

Figure1.7: DHT 11 Sensor Interfacing with Arduino

3. L293D (Motor Driver)

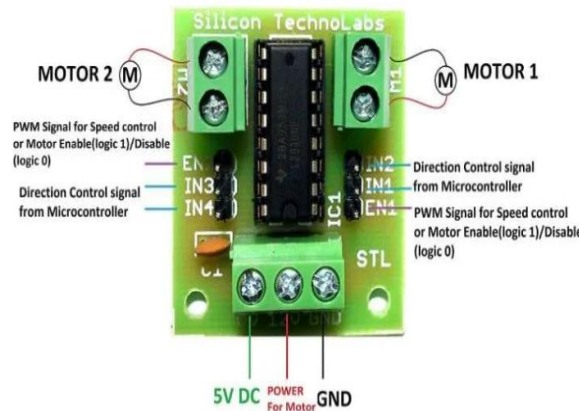

Figure1.8: L293D Motor Driver

The L293D is a dual H-bridge motor driver IC used to control the direction and speed of DC motors. It allows a microcontroller like Arduino to drive motors by providing sufficient current and enabling forward and reverse rotation. In this system, it is used to control motors for solar tracking and automated cleaning mechanisms.

4. Relay Module

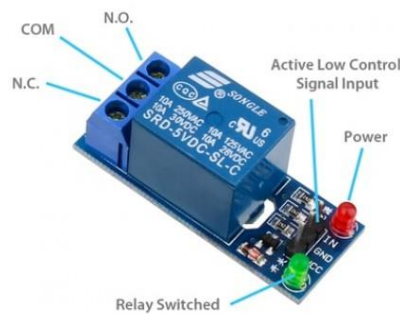

Figure1.9: Relay Module

A relay module is an electrically operated switch used to control high-voltage devices using a low-voltage signal from a microcontroller like Arduino. It provides isolation between the control circuit and high-power components such as water pumps or motors. In this system, it is used to switch the cleaning pump or other devices ON and OFF automatically.

5. DC Motor

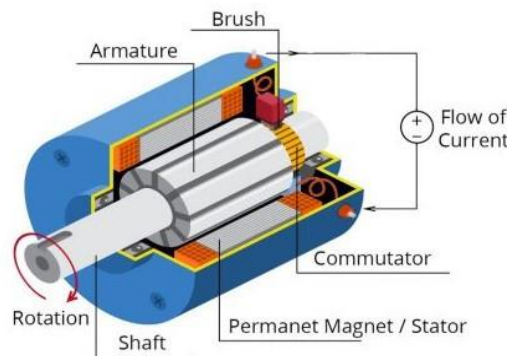

Figure1.10: DC Motor

A DC motor is an electromechanical device that converts direct current (DC) electrical energy into mechanical rotational motion. It is commonly used for driving moving parts such as solar panel rotation and cleaning mechanisms. In this system, the DC motor enables panel tracking and brush/wiper movement for automated cleaning.

6. Solar Brush

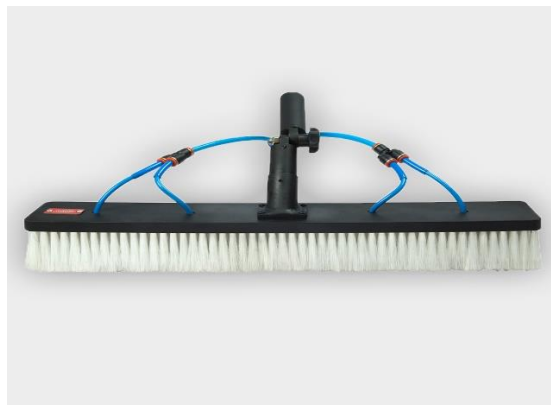

Figure1.11: Solar Brush Cleaner

A solar brush is a specialized mechanical cleaning component designed to effectively remove dust, dirt, and other particulate matter from the surface of solar panels without causing damage. It is typically made of soft, non-abrasive materials and is integrated with a motor-driven mechanism that enables uniform movement across the panel surface. In automated systems, the brush works in coordination with water spraying units and control systems to ensure thorough and efficient cleaning. This helps maintain maximum light absorption, improves energy output, and enhances the overall efficiency and lifespan of the solar photovoltaic system.

RESULTS AND DISCUSSION

1 Photos of Model



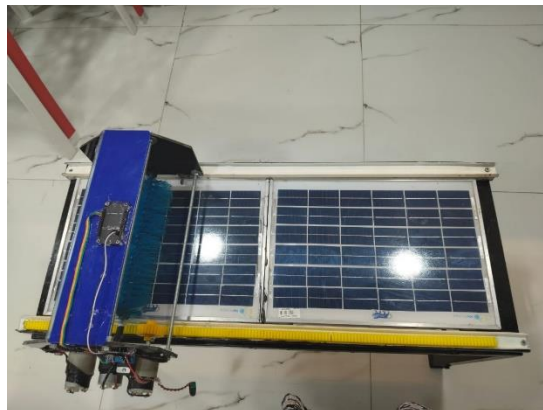

CONCLUSION

This study presents the design and development of a Smart Solar Tracker System integrated with an IoT-enabled automated cleaning mechanism aimed at maximizing the efficiency and reliability of solar photovoltaic (PV) systems. The research clearly demonstrates that key factors such as suboptimal panel orientation and dust accumulation significantly degrade system performance, leading to considerable energy losses. To address these challenges, the proposed system combines a dual-axis solar tracking mechanism with an intelligent, sensor-based automated cleaning system, ensuring optimal सूर्य exposure and maintaining panel cleanliness under varying environmental conditions.

The implementation of a real-time IoT-based monitoring and control framework further enhances system performance by enabling continuous data acquisition, remote accessibility, and intelligent decision-making. The integration of sensors, microcontrollers, and cloud-based platforms allows for effective monitoring of environmental parameters and system behavior, facilitating improved operational efficiency and predictive maintenance capabilities. Additionally, the automated cleaning mechanism optimizes water usage and reduces manual intervention, thereby lowering maintenance costs and improving system sustainability.

The results and analysis indicate that the proposed integrated system significantly improves energy output, enhances system reliability, and ensures consistent performance compared to conventional fixed and manually maintained PV systems. Moreover, the system offers scalability and adaptability, making it suitable for both small-scale installations and large solar farms. Despite minor challenges related to system complexity and initial investment, the long-term benefits in terms of efficiency, cost savings, and sustainability outweigh these limitations. In conclusion, the developed smart solar tracking and cleaning system represents a comprehensive and technologically advanced solution for modern solar energy applications. It not only addresses existing limitations in solar panel maintenance and performance optimization but also contributes to the advancement of intelligent and sustainable energy systems. This work lays a strong foundation for future innovations in smart renewable energy technologies, particularly through the integration of advanced analytics, automation, and intelligent control strategies.

REFERENCES

1. A Solar Panel Cleaning Robot Design and Applica, Omur Akyazi, Erdinc Sahin, Timur Ozsoy, Mehmet Algul4, European Journal of Science and Technology, m 25 October 2019).
2. Solar Energy Monitoring System by IOT, K. G. Srinivasan, Dr. K. Vimaladevi, Special Issue Published in Int. of Advanced Networking & Applications (IJANA), January 2019.
3. Automated Solar Panel Cleaning System using IoT Milan Vaghani1, Jayesh Magtarpara2, Keyur Vahani3, Jenish Maniy, Prof. Rajiv Kumar Gurjwar, International Research Journal of Engineering and Technology (IRJET), n 09 September 2020.
4. Automatic Cleaning of Solar Panel, Nikhath Anjum, Keerthana International Journal of Engineering Research & Technology (IJERT), 2018.

5. IoT-Based Automated Solar Panel Cleaning and Monitoring Technique Shasoto Biswas a Muhibul Haque Bhuyan a* and Md. Kamrul Hassan, Journal of Engineering Research and Reports: 02/09/2023.
6. Enhancing Photovoltaic Panel Efficiency with an IoT-Enabled Robotic Cleaning System – A Comprehensive Review Mohammed Ghadhban Ahmed, Anmar Aidi Shareef, Engineering and Technology Journal e-ISSN, e 06 June 2023.
7. IoT Based Solar Powered Smart Waste Management System with Real Time Monitoring-An Advancement for Smart City Planning by Md. Humaun Kabir, Sujit Roy, Md. Tofail Ahmed & Mahmudul Alam, Global Journal of Computer Science and Technology: G Interdisciplinary, 0 Year 2020.
8. Automatic Solar Panel Cleaning System Using IoT 1K. Abdul Khadar, 2K. Sai Ganesh, 3E. Sai Preetham, 4S. Chandra Shaker, 5Dr.P.V. Venkateswara Rao, International Journal Reative Research Thoughts (IJCRT),
9. IOT Based Solar Tracking and Cleaning System, Masooma Jafri, Ankur Yadav, Anushree Srivastava, Dharmendra Kumar, Vishal Thapa, Devesh Jaiswal, International Journal of Innovative Research in Technology,2023.
10. Smart PV Panel Cleaning System and Dual Axis Tracking, Monitoring using IoT, UK. Balu Ganesh, J. Ero Geo Sathyan, V. Gopala Krishnan, T. Kaja Mohaidin Aasik, A. Sheik Sidthik5, International Journal of Research Publication and Reviews,
11. IoT based photovoltaic monitoring system application, W Priharti, A F K Rosmawati2 and I P D Wibawa, International Conference on Engineering, Technology and Innovative Researches,
12. IoT Based Solar Panel Tracking System with Weather Monitoring System, K. Dinesh a,1, Lakshmi Priya. A, Preethi. T, Sandhya. M, Sangeetha. P, Recent Trends in Intensive Computing,
13. IoT Enabled Solar Power Monitoring System Prof. Atul Ghute, Shrirang Futane2 Rushikesh Dambale3, Athar Shaikh4, Nikhil Bhav5, Vaibhav Chaur, International Journal of Innovative Research in Science, Engineering and Technology (IJIRSET), 6 JUNE 2021.
14. Automated Solar Panel Cleaning System using IoT, Milan Vaghani1, Jayesh Magtarpara2, Keyur Vahani3, Jenish Maniya4, Prof. Rajiv Kumar Gurjwar5, International Research Journal of Engineering and Technology (IRJET).
15. A Review on Solar Panel Cleaning Robot using IoT Reeka Narang1, Varsha Sharma2, International Research Journal of Engineering and Technology (IRJET), 11 NOV 2019.
16. Automatic Water and Dust Detector Based Solar Panel Cleaning System Km Saba Khan, Thanuku Hemanth Kumar, Sanapala Sri Naveen, Kottiyada Sai Yochan4, Thripuram Balarama Krishna Murthi5, and Mandeep Singh, (JETIR),
17. Design And Realization of Autonomous Cleaning Robot For Solar Panel Applicatons K.S. Balajhi, Dr. S. Sumathi, Dr.R. Uthirasamy, S. Manikan, J. Gokul Kannan, N. Abinash, (Jetir). Org,
18. Smart solar photovoltaic panel cleaning system, Nasib Khadka, Aayush Bista, Binamra Adhikari, Ashish Shrestha1,2 and Diwakar Bista1, International Conference on Sustainable Energy and Green Technology,2019.
19. Remote Controlled Unmanned River Cleaning Bot, Akash Shahu, International Journal of Engineering Research & Technology (IJERT), n 06 April 2021.

20. A Smart-Home System to Unobtrusively and Continuously Assess Loneliness in Older Adults
Johanna Austin, Hiroko H. Dodge, Thomas Riley, Peter G. JACOBS, Stephen Thielk, And Jeffrey Kaye¹, Point-Of-Care Technologies, d 20 May 2016.
21. IoT-Enabled Smart Solar Energy Management System for Enhancing Smart Grid Power Quality and Reliability
Md. Tanvir Shaheda, b, *, Md. Mofizol Haqueeb, Suma Akterb, Sumon Mianb, Ripan Chandra Shilb
^aDepartment of EEE,
22. Smart Iot Based Solar Panel Cleaning System, Sathish Singarapu, K Swaraja, Madhu Kirola, ICMPC 2023.
23. Smart solar photovoltaic panel cleaning system
Nasib Khadkar, Aayush Bista, Binamra Adhikari, International Conference on Sustainable Energy and Green Technology 2019.